

Heating and cooling

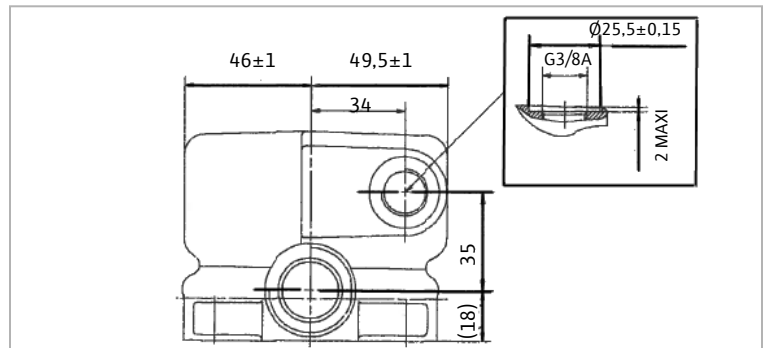

Inline asynchronous circulators for heating application

Type : RSL and DY

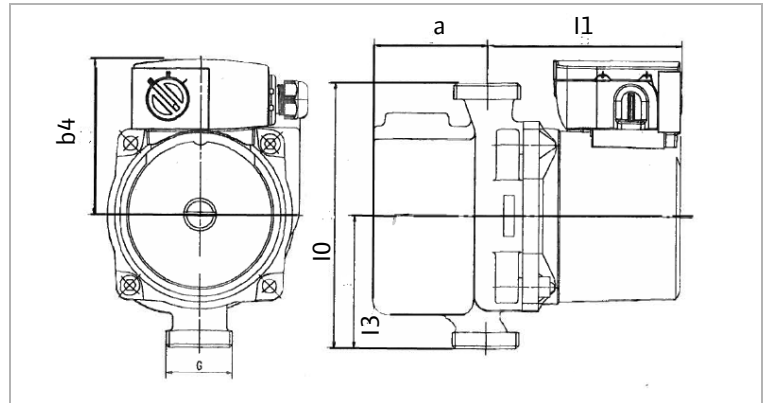

	Thread	Dimensions				
	G	l0	l3	l1	a	b4
RSL15/4	1"	130	65	96,6	56,5	72,5
RSL15/5				96,6		72,5
RSL15/6				96,6		76
RSL15/6 Compact				96,6		72,5
RSL15/7				109,6		76

Inline asynchronous circulators for heating application

Type : RSL and DY

	n l/m	P1 W	I A	Capacitor µf/VDB
RSL15/4	max 2050	65	0,28	2 / 400
	1650	46	0,20	
	min 1300	30	0,13	
RSL15/5	max 2300	85	0,37	2 / 400
	2000	60	0,27	
	min 1450	39	0,18	

RSL 15/4-3

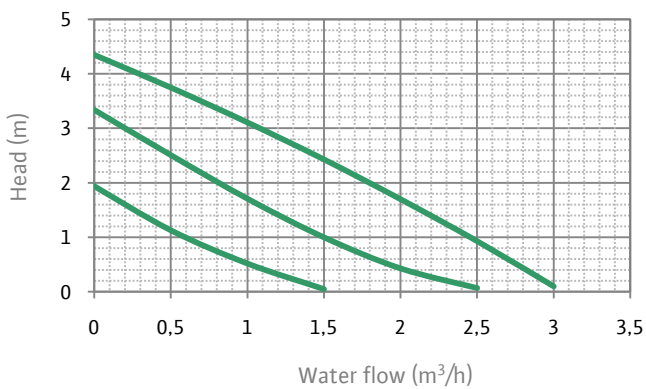

RSL 15/5-3

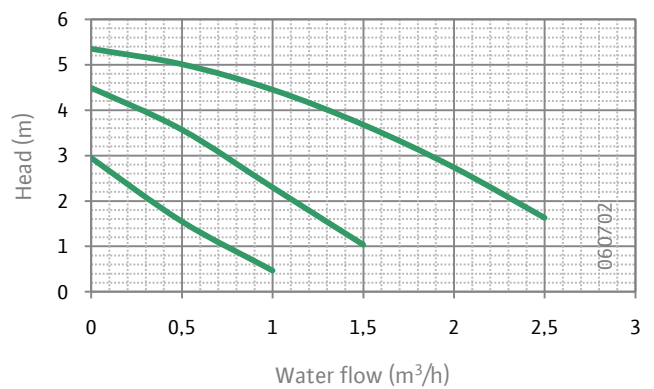

Inline asynchronous circulators for heating application

Type : RSL and DY

	n l/m	P1 W	I A	Capacitor µf/VDB
RSL15/6	max 2200	93	0,40	2,6 / 400
	1900	67	0,30	
	min 1450	46	0,20	
RSL15/6 Compact	max 2400	85	0,37	2 / 400
	1900	59	0,27	
	min 1100	37	0,18	
RSL15/7	max 2450	132	0,58	3,5 / 400
	2250	92	0,42	
	min 1850	62	0,30	

RSL 15/6-3

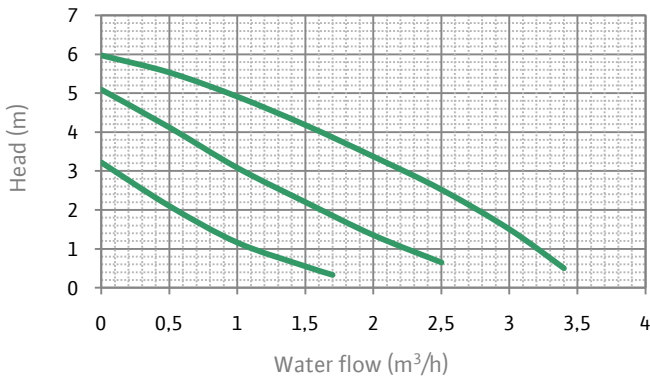

RSL 15/6-3 Compact

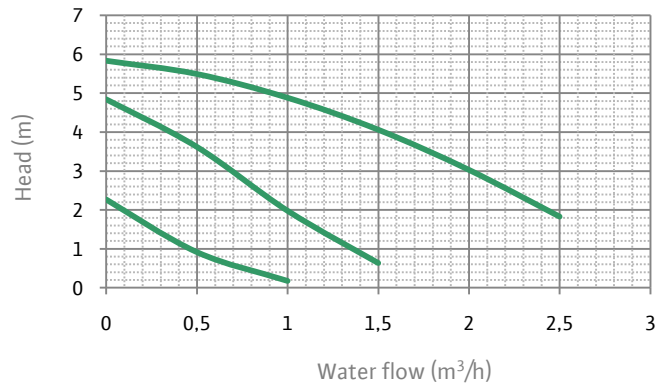

RSL 15/7-3

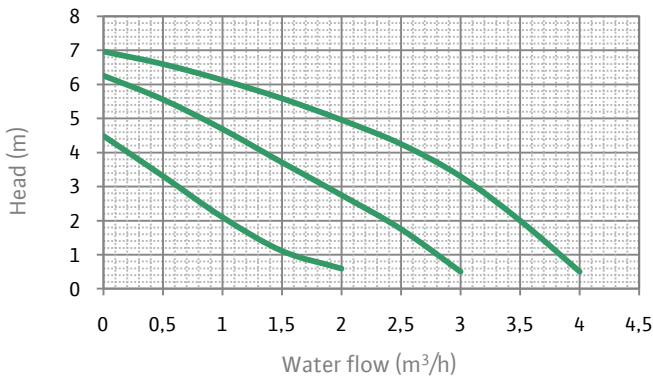

Specific asynchronous circulators for heating application

Magic circulator : Type MSL 12/...



Also available as Integrated Circulator

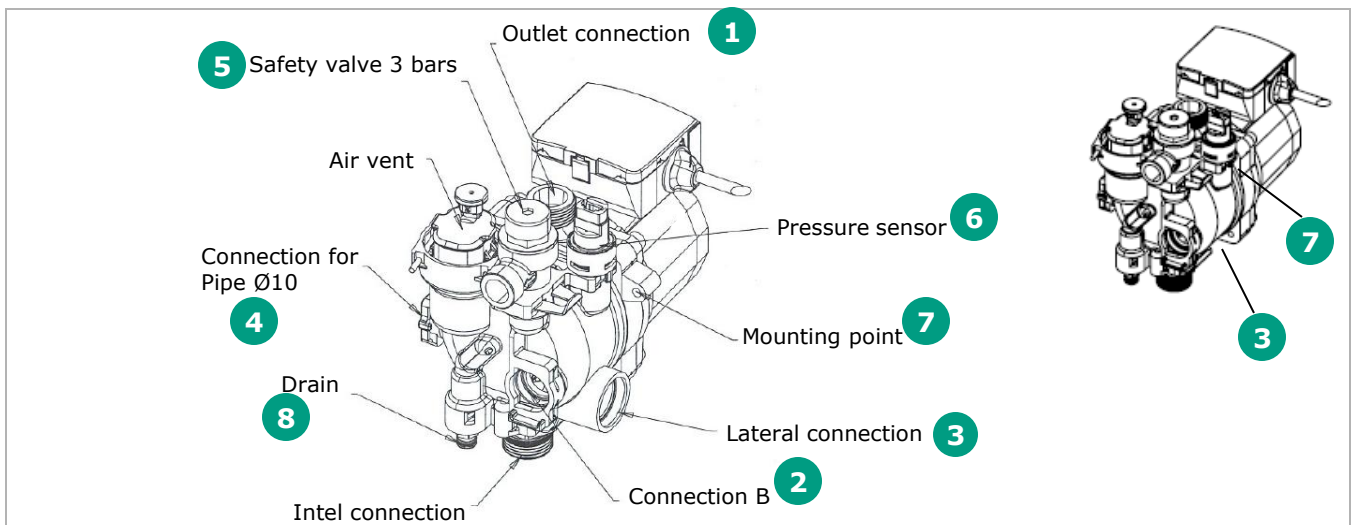
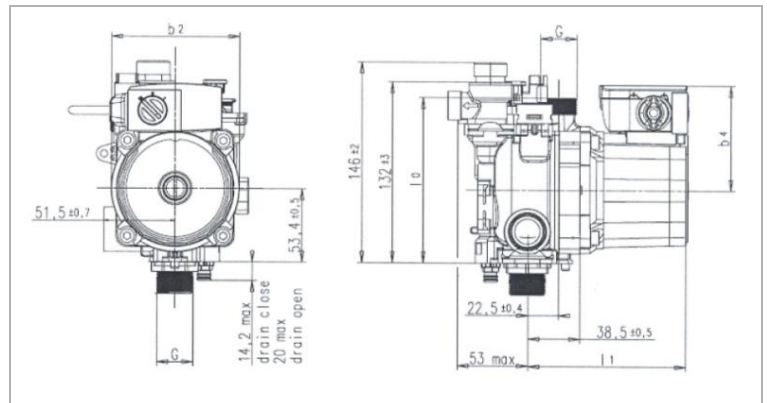

1	Outlet connection (pressure side)	Threaded 3/4" or clip pipe Ø18
2	Connection B	Opened or closed
3	Lateral connection	With or without
4	Connection for pipe Ø10	Opened or closed
5	Safety valve 3 bars	With or without
6	Pressure sensor	With or without
7	Mounting point	With or without
8	Drain	With or without

Specific asynchronous circulators for heating application

Magic circulator : Type MSL 12/...

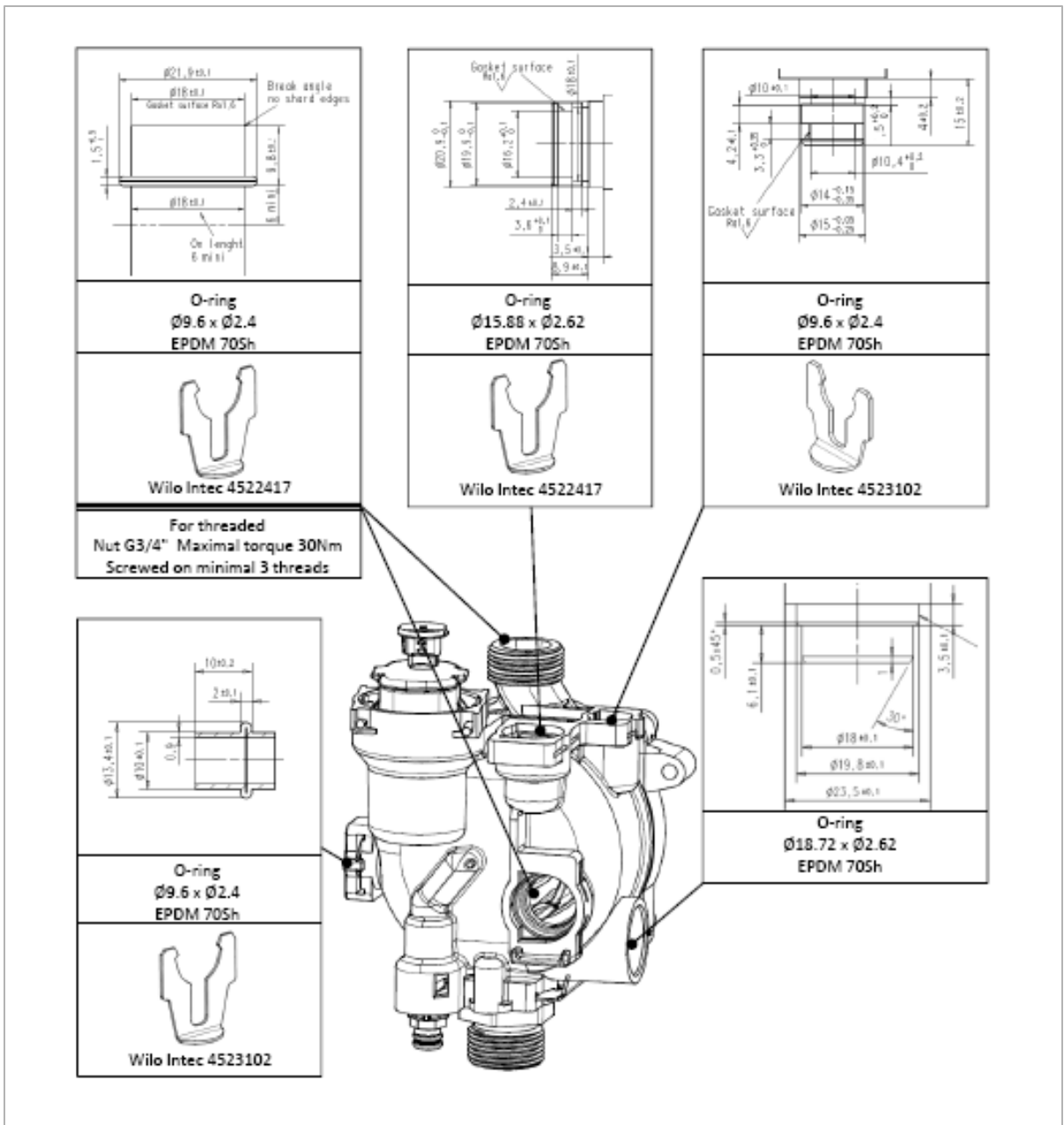

	Thread	Dimensions			
	G	I0	I1	b2	b4
MSL12/Premium	3/4"	120	116,2	92,5	72,5
MSL12/5	3/4"	120	116,2	92,5	72,5
MSL12/6	3/4"	120	116,2	92,5	76
MSL12/6 Compact	3/4"	120	116,2	92,5	72,5
MSL12/7	3/4"	120	129,2	92,5	76

Specific asynchronous circulators for heating application

Magic circulator : Type MSL 12/...

	n l/min	P1 W	I A	Capacitor µf/VDB
MSL12/Premium	max 2300	66	0,29	2 / 400
	2190	48	0,22	
	min 1720	35	0,16	
MSL12/5	max 2310	84	0,37	2 / 400
	2040	59	0,28	
	min 1560	40	0,18	

MSL 12/Premium

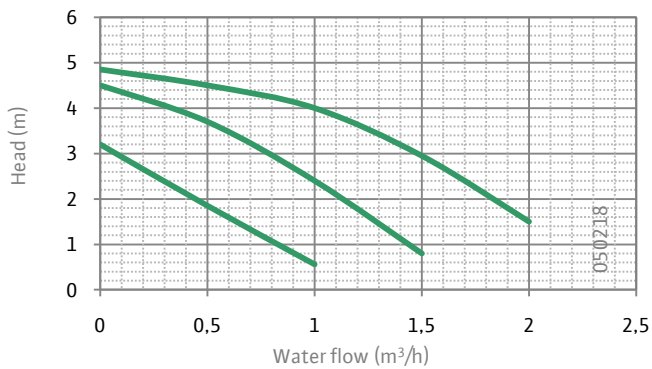

MSL 12/5-3

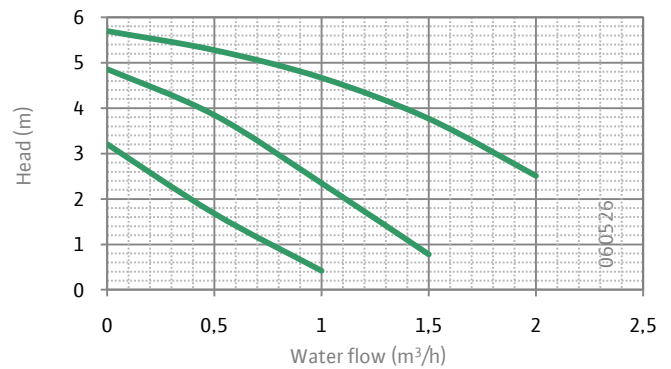

Specific asynchronous circulators for heating application

Magic circulator : Type MSL 12/...

	n l/min	P1 W	I A	Capacitor µf/VDB
MSL12/6	max 2400	86	0,38	2,6 / 400
	2050	63	0,28	
	min 1730	42	0,19	
MSL12/6 Compact	max 2300	85	0,37	2 / 400
	1900	58	0,27	
	min 1100	36	0,17	
MSL12/7	max 2600	120	0,53	3,5 / 400
	2300	89	0,41	
	min 2040	59	0,27	

MSL 12/6-3

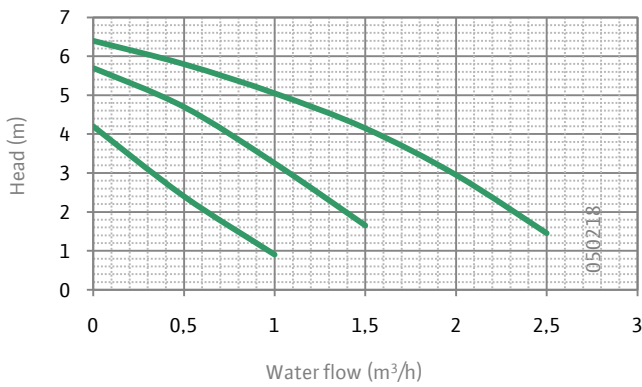

MSL 12/6 Compact-3

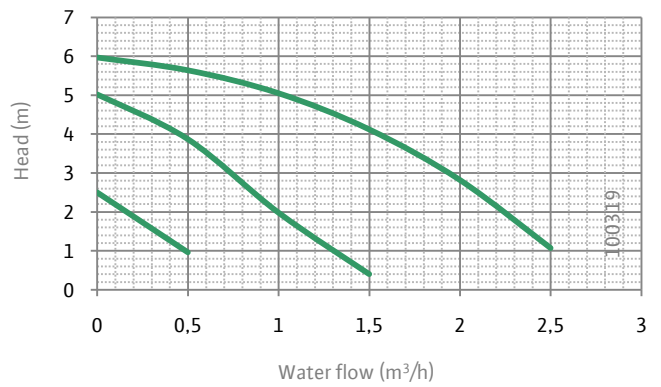

MSL 12/7-3

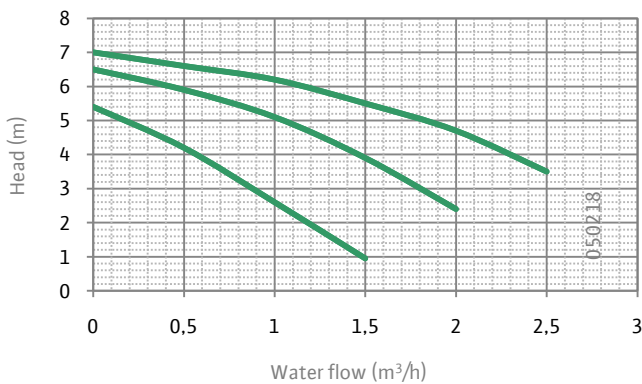

Specific asynchronous circulators for heating application

Magic circulator : accessories

Pressure Sensor



Function :

Proportional pressure sensor

Connector:

Hedge connector Rast 2.5mm / 4 ways

Counter part :

STOCKO Rast 2.5 (ref: MFM7238 or MKF13474)

1 : GND - 2 : VCC - 3 : N/A - 4 : SIGNAL

Characteristics :

Input voltage : 5V DC +/- 0.2V / max. 10mA

Pressure range : 0 to 3,5 bars

0,5 bars : 1,40 Vdc +/-0,110Vdc

2,5 bars : 2,5 Vdc +/-0,275 Vdc

Safety valve



3 bars outlet connection : 1/2"

Drain plug



Function :

Drain circulator

Specific asynchronous circulators for heating application

Type : NFSL and DNFS

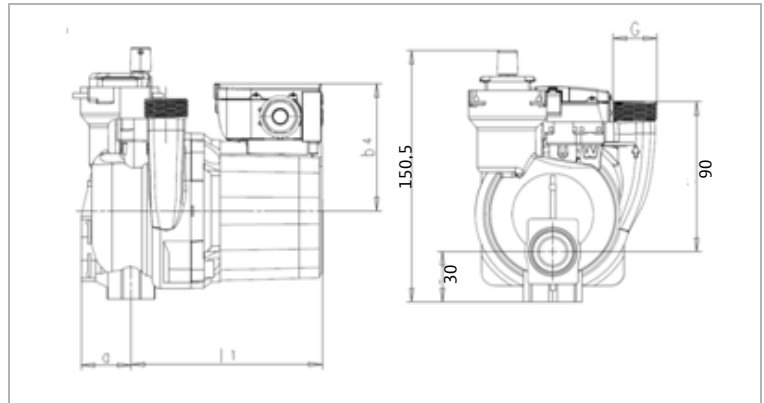

d	4,1
e	25
e1	31,5
e2	50,75
f	6
g	22
h	49

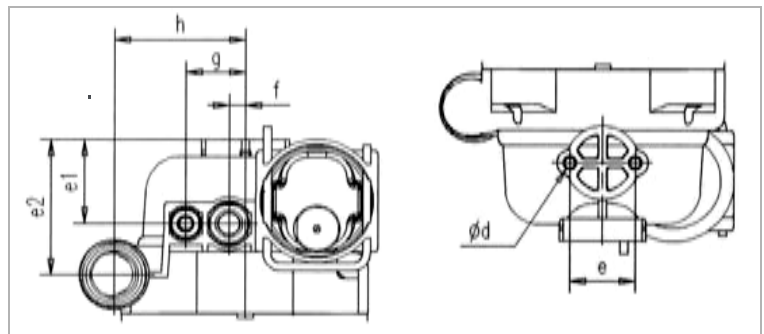

	Thread	Dimensions		
	G	l1	a	b4
NFSL12/Premium – DNFS,/Premium-12	3/4"	114	29,8	72,5
NFSL12/5 HE – DNFS,/43 HE-12	3/4"	114	29,8	72,5
NFSL12/6 HE – DNFS,/53 HE-12	3/4"	114	29,8	72,5
NFSL12/6 HEP – DNFS,/53 HEP-12	3/4"	114	29,8	76
NFSL12/6 Compact – DNFS,/53 Compact-12	3/4"	114	29,8	72,5
NFSL12/7 HE – DNFS,/63 HE-12	3/4"	127	29,8	76

Specific asynchronous circulators for heating application

Type : NFSL and DNFS

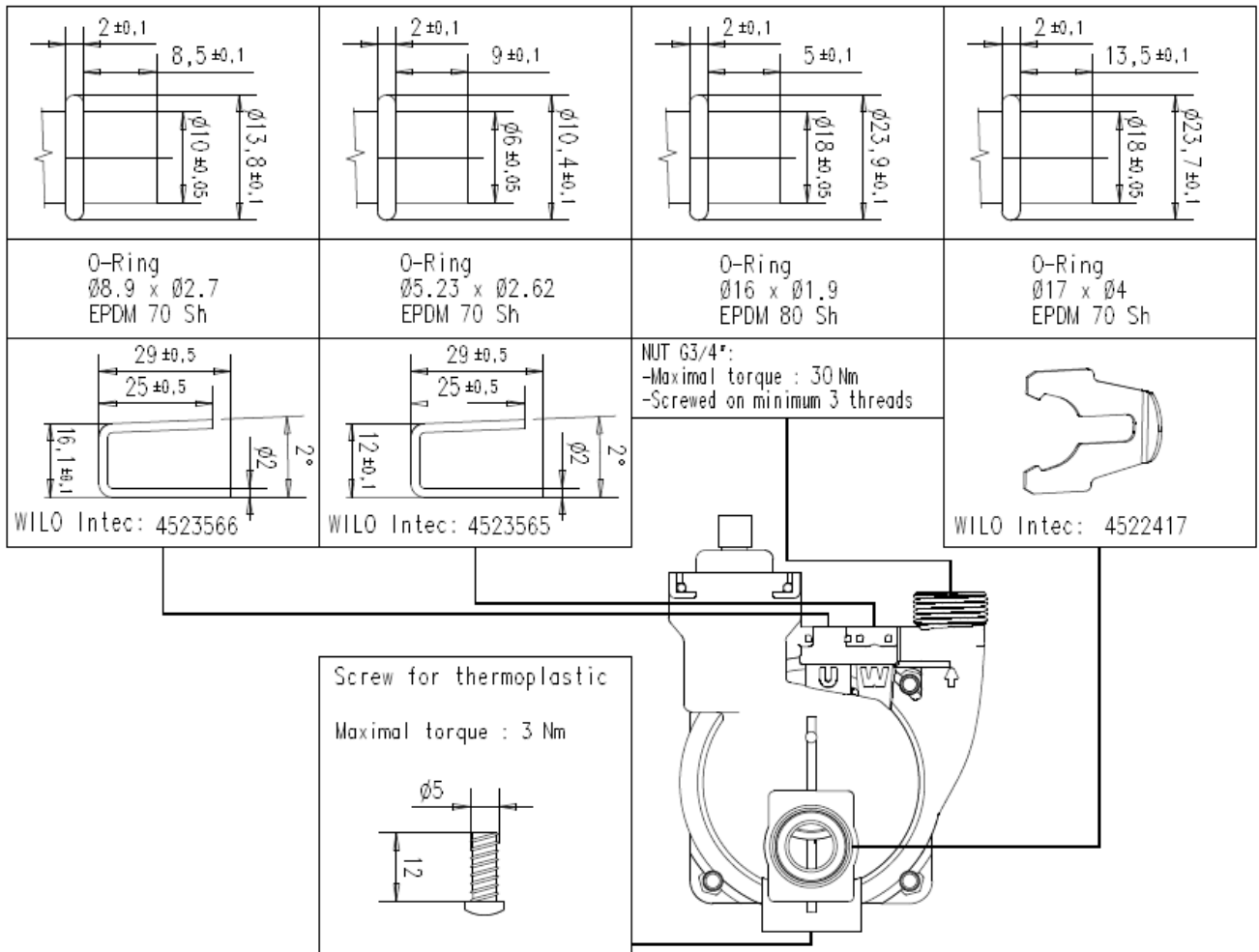

Please note that the connections U and W can be delivered open or closed

Specific asynchronous circulators for heating application

Type : NFSL and DNFS

	n l/min	P1 W	I A	Capacitor µf/VDB
NFSL12/Premium DNFS./Premium-12	max 2460	59	0,26	2/400
	1950	49	0,23	
	min 1710	33	0,15	
NFSL12/5 HE DNFS./43 HE-12	max 2400	77	0,34	2/400
	2000	56	0,26	
	min 1650	36	0,17	
NFSL12/6 HE DNFS./53 HE-12	max 2300	82	0,37	2/400
	2030	58	0,27	
	min 1720	39	0,18	

NFSL 12/Premium-3

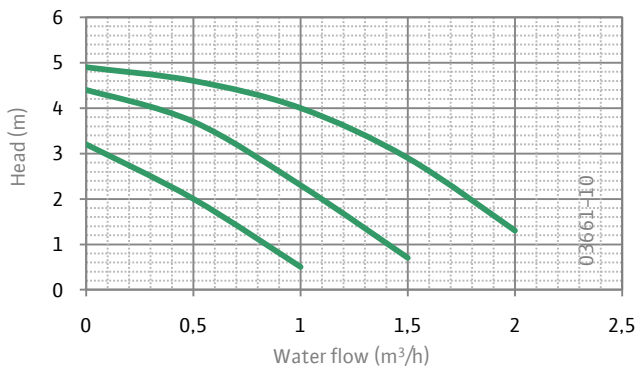

NFSL 12/5 HE-3

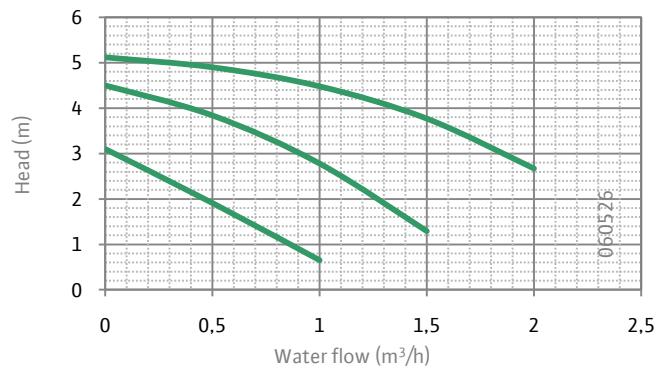

NFSL 12/6 HE-3

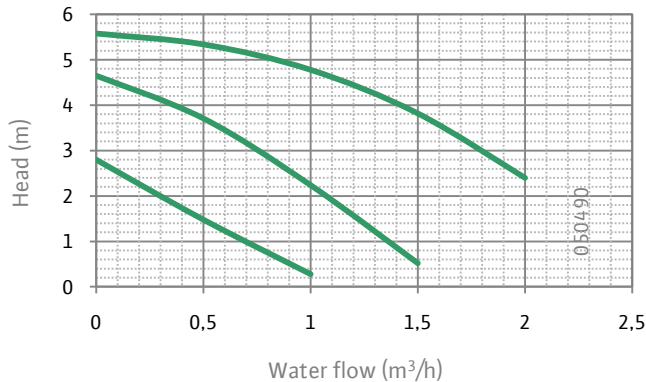

Specific asynchronous circulators for heating application

Type : NFSL and DNFS

	n l/min	P1 W	I A	Capacitor µf/VDB
NFSL12/6 Compact DNFS./53-12 Compact	max	2400	84	0,36
		2000	57	0,26
	min	1200	36	0,18
NFSL12/6 HEP DNFS./53 HEP-12	max	2400	83	0,37
		2130	58	0,27
	min	1820	40	0,18
NFSL12/7 HE DNFS./63 HE-12	max	2570	118	0,52
		2450	78	0,36
	min	1700	60	0,28

NFSL 12/6 Compact-3

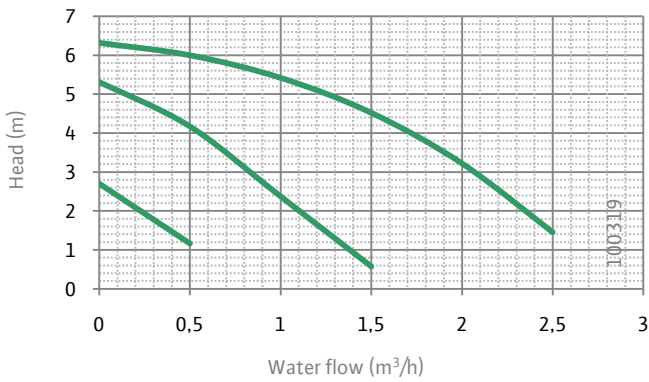

NFSL 12/6 HEP-3

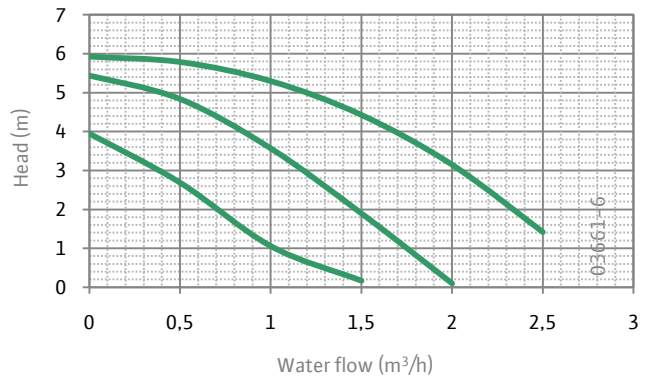

NFSL 12/7 HE-3

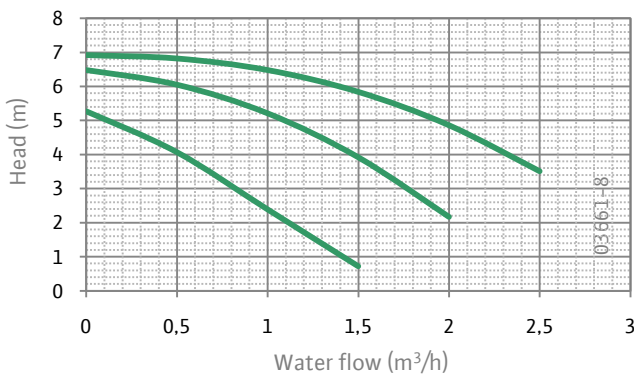

Specific asynchronous circulators for heating application

Type : BSL and DBS

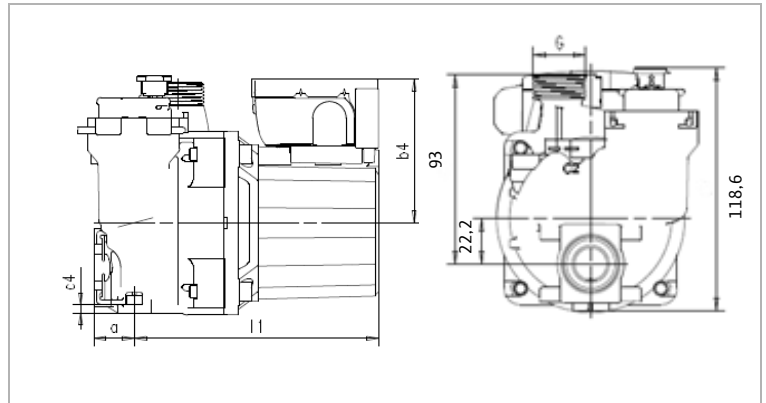
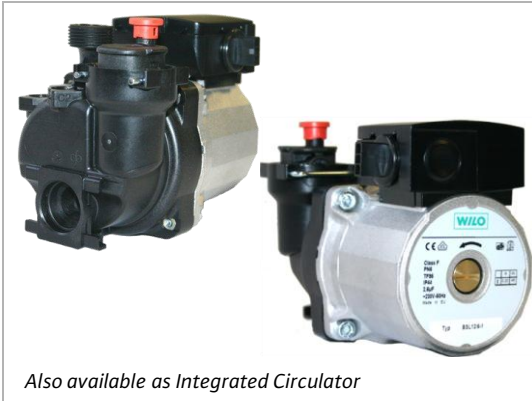

e1	13
e2	42,5
e3	20
f	6,4
g	31,3
h	14,5

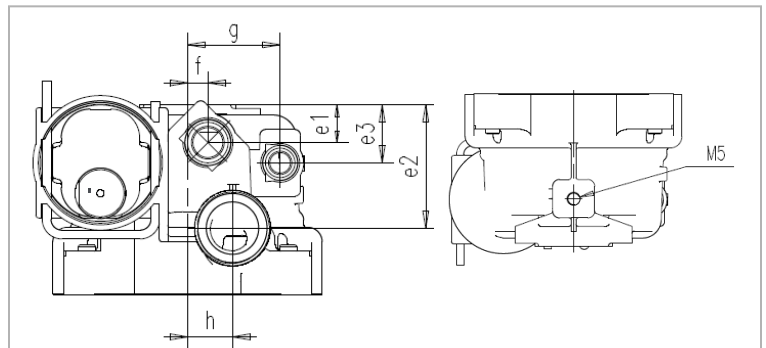

		n l/min	P1 W	I A	Capacitor µf/VDB
BSL12/4.1 HE DBS.34 HE-12	max	2190	77	0.30	2 / 400
		1950	53	0.23	
	min	1530	37	0.16	
BSL12/5 HE DBS.43 HE-12	max	2300	83	0.36	2 / 400
		2080	58	0.27	
	min	1500	40	0.18	
BSL12/6 HE DBS.53 HE-12	max	2500	86	0.37	2.6 / 400
		2360	59	0.26	
	min	1820	43	0.19	
BSL12/7 HE DBS.63 HE-12	max	2650	117	0.50	3.5 / 400
		2520	78	0.37	
	min	2060	56	0.26	

	Thread	Dimensions			
	G	l1	a	b4	c4
BSL12/4.1 HE - DBS.34 HE-12	3/4"	124,1	20,3	72,5	4,3
BSL12/5 HE - DBS.43 HE-12	3/4"	124,1	20,3	72,5	4,3
BSL12/6 HE - DBS.53 HE-12	3/4"	124,1	20,3	76	4,3
BSL12/7 HE - DBS.63 HE-12	3/4"	137,1	20,3	76	4,3

Specific asynchronous circulators for heating application

Type : BSL and DBS

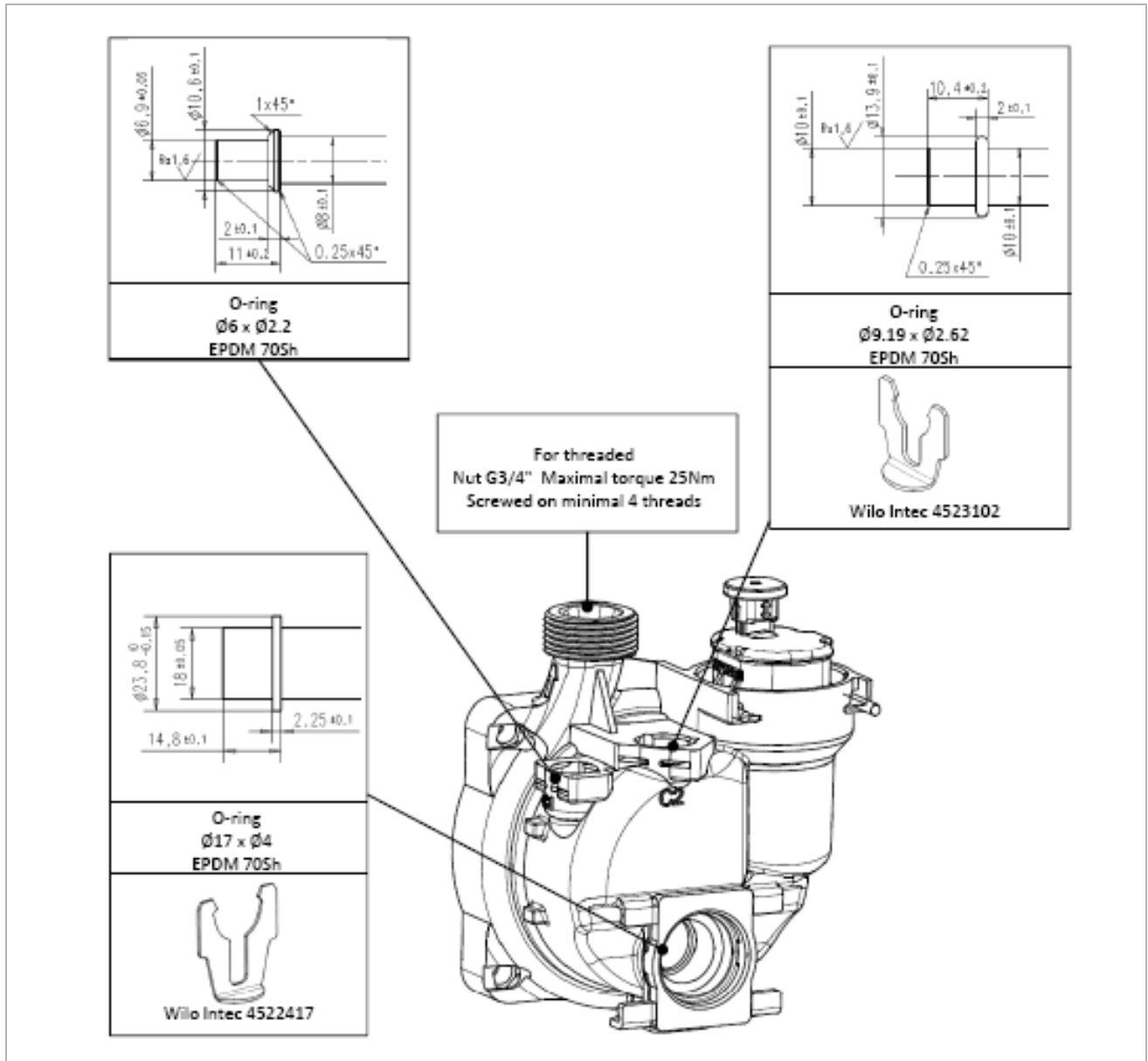

Specific asynchronous circulators for heating application

Type : BSL and DBS

BSL 12/4.1 HE-3

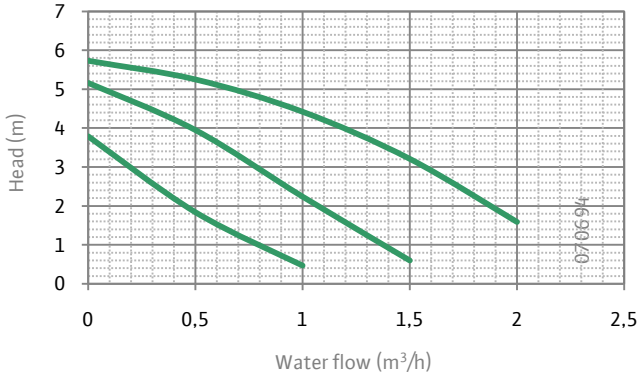

BSL 12/5 HE-3

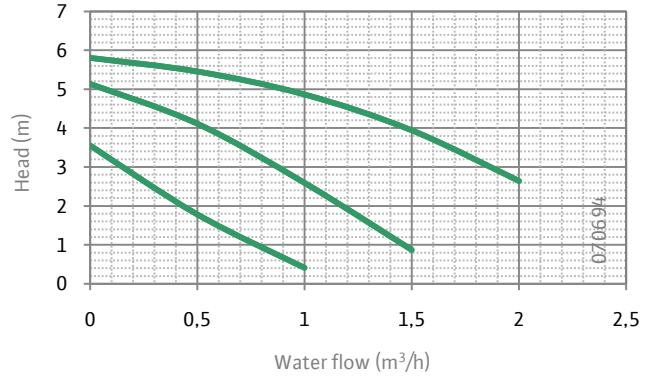

BSL 12/6 HE-3

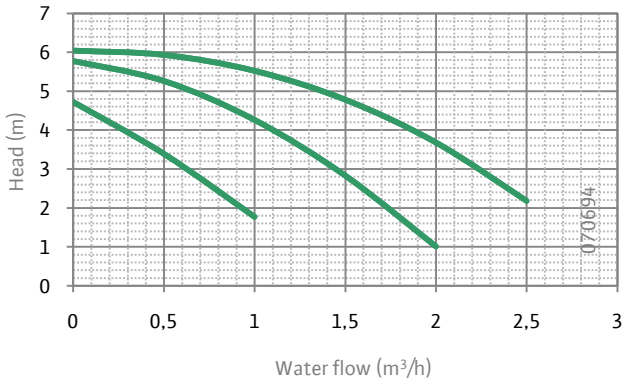

BSL 12/7 HE-3

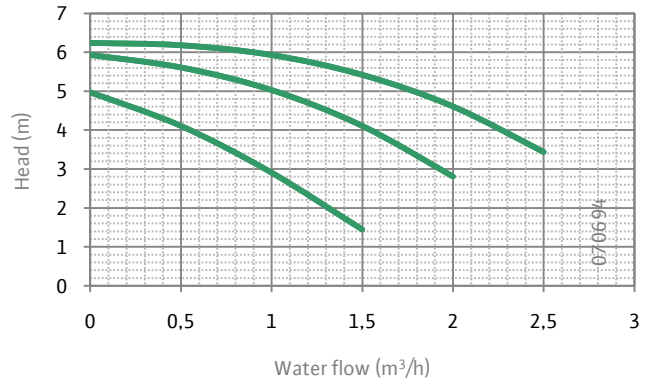

Electronic circulators for heating application

Type PWM-X

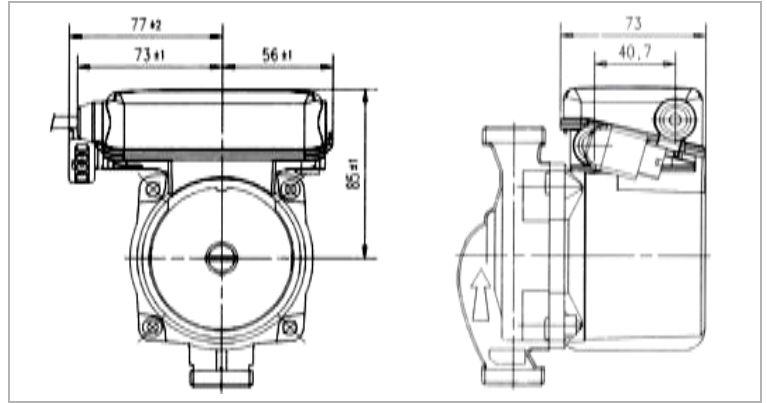

RS../6 PWM-X

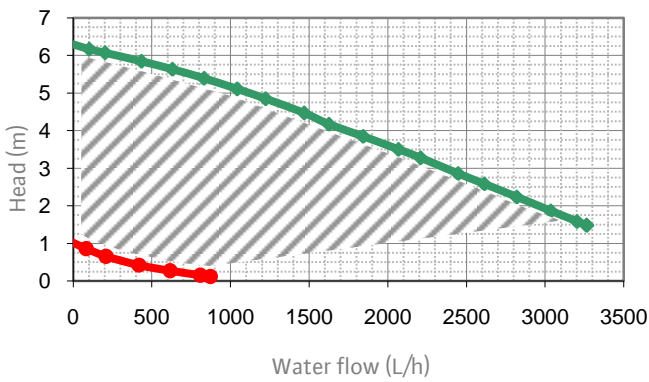

RS 25/7 PWM-X

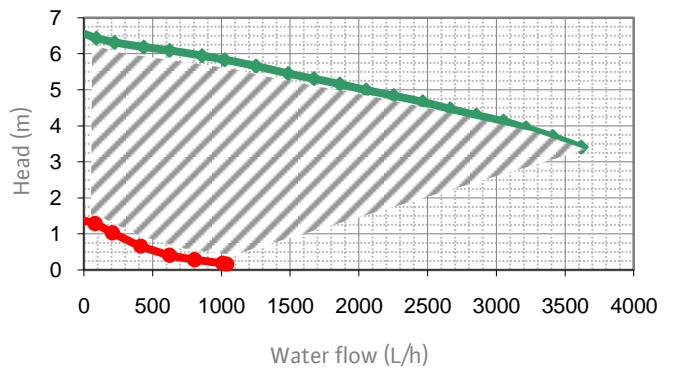

RSL 15/6 Ku PWM-X

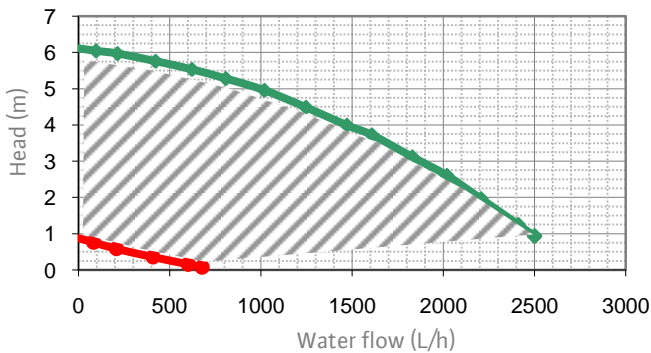

	n 1/min	P1 W	I A
RS../6 PWM-X	max	2200	92
RSL 15/6 Ku PWM-X	min	400	31
RS../7 PWM-X	max	2750	124
	min	450	40

Electronic circulators for heating application

Type E../1-5

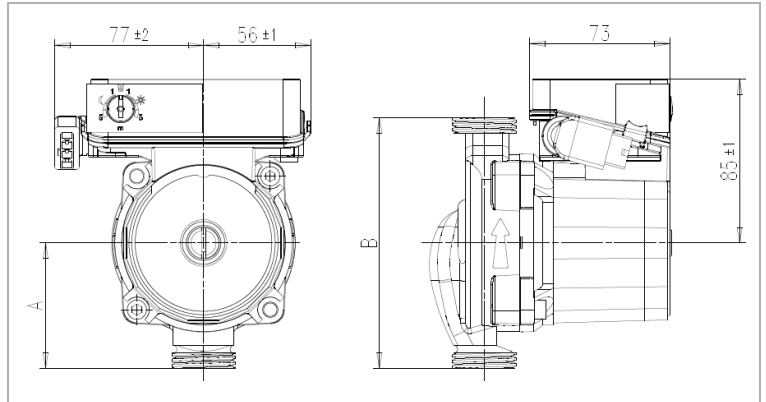
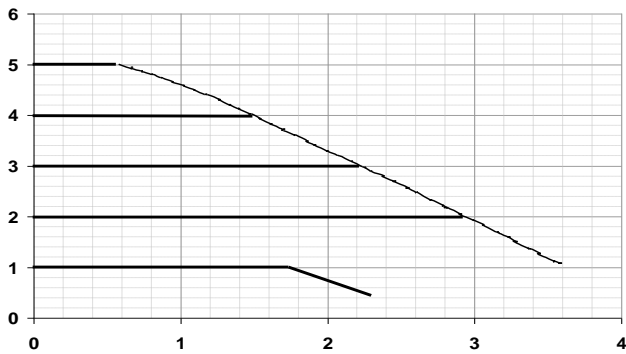
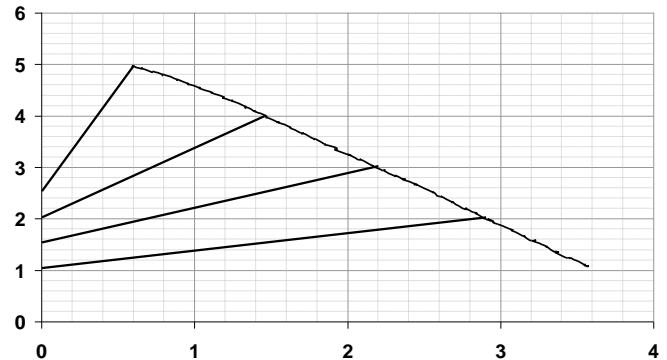
 Δp -c (constant) Δp -v (variable)

Cast Iron Pump Housings	Thread	Dimensions	
	G	A	B
E15/1-5	1"	65	130
E25/1-5	1"1/2	65	130
E25/1-5	1"1/2	90	180
E../1-5	n	P1	I
	1 / min	W	A
	max	2450	69
min	1750	54	0,24

Cast Iron Pump Housings	Thread	Dimensions	
	G	A	B
E20/1-5	1"1/4	65	130
E30/1-5	2"	90	180
E../1-5	n	P1	I
	1 / min	W	A
	max	2300	90
min	1150	48	0,21

Data for composite pump housings available on request

Nota bene : tolerances of each curve are according to EN 1151-1:2006

Sanitary hot water



Asynchronous circulators for sanitary application

Type : Z15

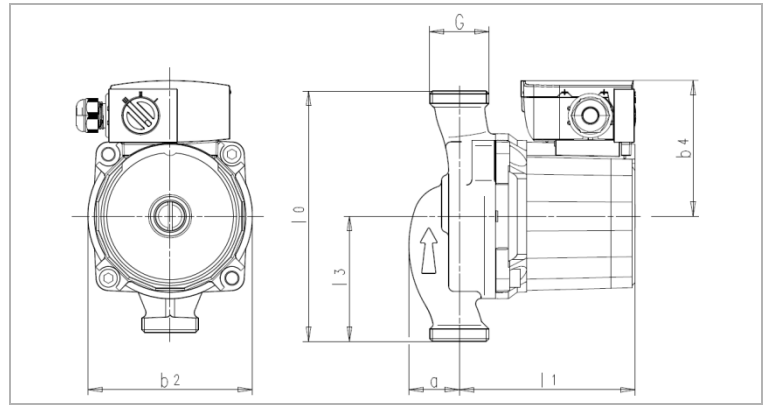

Z15/4-3

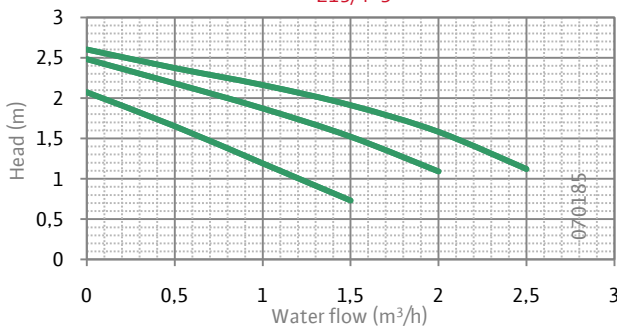

Z15/5-3

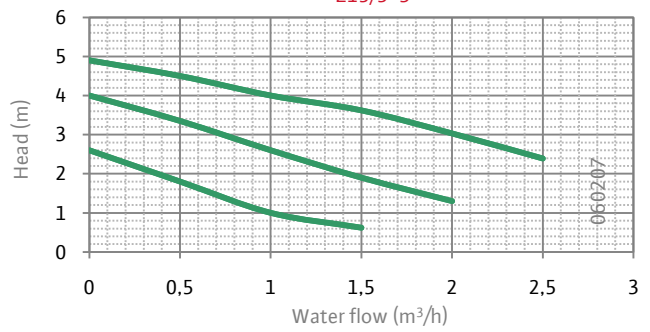

Z15/6-3

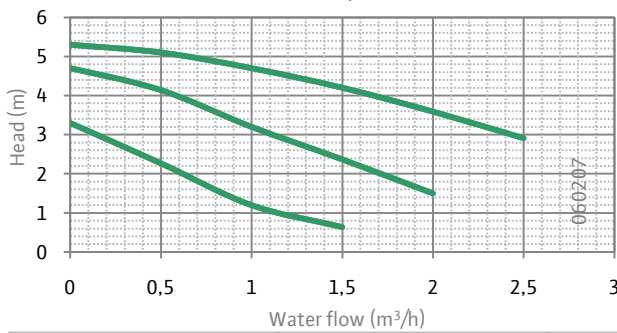

Z15/7-3

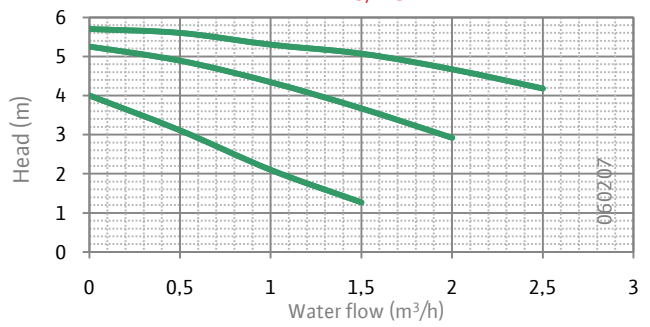

	n		P1 W	I A	Capacitor µF / VDB		
	1/min						
Z15/4	max	2500	58	0.24	2 / 400		
	min	2000	28	0.12			
Z15/5	max	2100	89	0.39	2.6 / 400		
	min	1700	64	0.29			
Z15/6	max	2300	87	0.38	2.6 / 400		
	min	1500	44	0.20			
Z15/7	max	2500	122	0.54	3.5 / 400		
	min	1700	64	0.29			
	Thread		Dimensions				
	G	I0	I1	I3	a	b2	b4
Z15/4	1"	130	96.6	65	31.7	92.5	72.5
Z15/5			96.6				76
Z15/6			96.6				
Z15/7			109.6				

Asynchronous circulators for sanitary application

Type: Z20

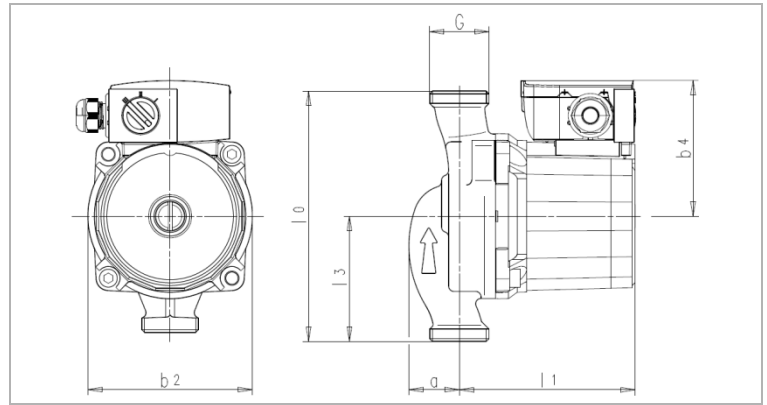

Z20/5

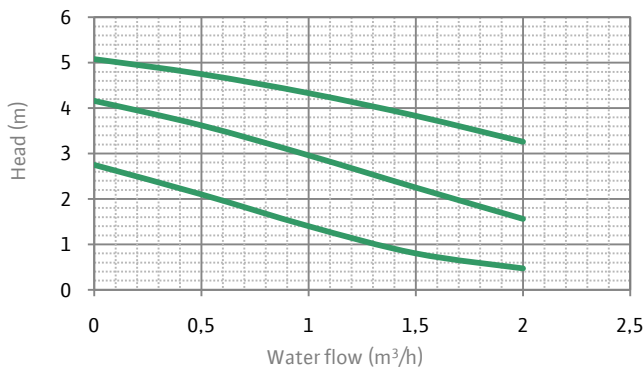

Z20/6

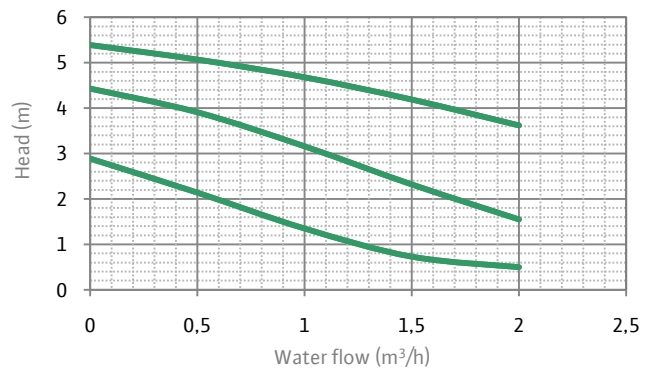

	n l/m	P1 W	I A	Capacitor µf/VDB
Z20/5	max	2150	89	0,39
		1600	66	0,29
	min	1050	45	0,20
Z20/6	max	2200	99	0,41
		1900	74	0,32
	min	1200	50	0,22

	Thread	Dimensions					
	G	l0	l3	l1	a	b2	b4
Z20/5	1"	140	70	96,6	32,2	92,5	76
Z20/6							

Asynchronous circulators for sanitary application

Type : Z25

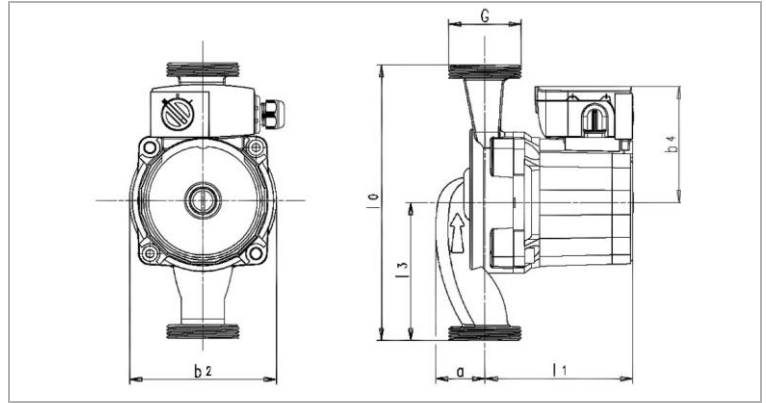

Z25/5

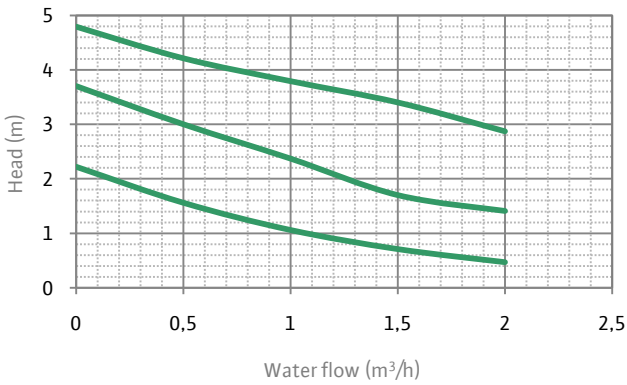

Z25/6

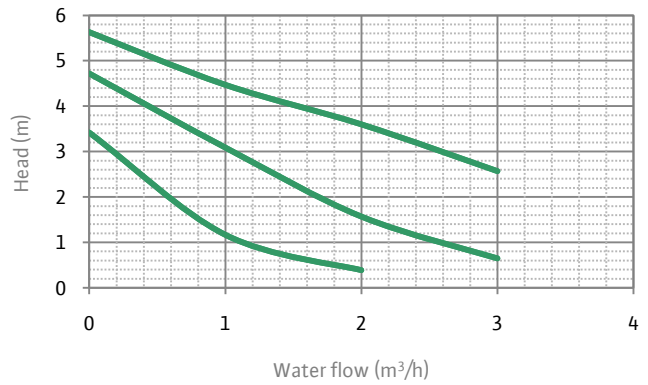

	n l/min	P1 W	I A	Capacitor µf/VDB
Z25/5	max	2150	89	2,6 / 400
		1600	66	
	min	1050	45	
Z25/6	max	2200	99	2,6 / 400
		1900	74	
	min	1200	50	

	Thread	Dimensions					
	G	l0	l3	l1	a	b2	b4
Z25/5	1"1/2	180	90	96,6	31,7	92,5	76
Z25/6							

Asynchronous circulators for sanitary application

Type : ZRS Ku and NSC

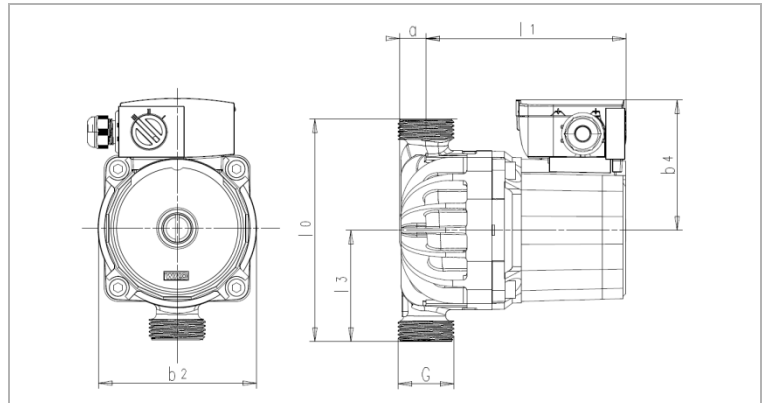

Connections G3/4 " or G1 " :

- > Maximal torque : 40 Nm
- > Screwed on minimum 3 threads
- > Gasket (EP856, EP80/2 or equivalent)
 - Ø24 x Ø16 x 2.1 (G3/4")
 - Ø30 x Ø21 x 2.1 (G1")

		n l /min	P1 W	I A	Capacitor µf /VDB
ZRS../2 Ku NSC10..	max	2100	48	0,21	1,6 /400
	med	1860	32	0,15	
ZRS../4 Ku NSC15..	max	2600	55	0,24	2 /400
		2500	39	0,18	
	min	2100	26	0,12	
ZRS../6 Ku NSC25..	max	2450	85	0,38	2,6 /400
		2000	63	0,29	
	min	1450	45	0,21	
ZRS../7 Ku NSC30..	max	2650	115	0,51	3,5 /400
		2400	86	0,40	
	min	1900	62	0,29	

	Thread	Dimensions					
	G	l0	l1	l3	a	b2	b4
ZRS12/2 Ku – NSC10-12	3/4"	130	116,5	65	15,5	92,5	72,5
ZRS12/4 Ku – NSC15-12			116,5				72,5
ZRS12/6 Ku – NSC25-12			116,5				76
ZRS12/7 Ku – NSC30-12			129,5				76
ZRS15/2 Ku – NSC10-15	1"	130	116,5	65	15,5	92,5	72,5
ZRS15/4 Ku – NSC15-15			116,5				72,5
ZRS15/6 Ku – NSC25-15			116,5				76
ZRS15/7 Ku – NSC30-15			129,5				76

Asynchronous circulators for sanitary application

Type : ZRS Ku and NSC

ZRS ../-2 Ku

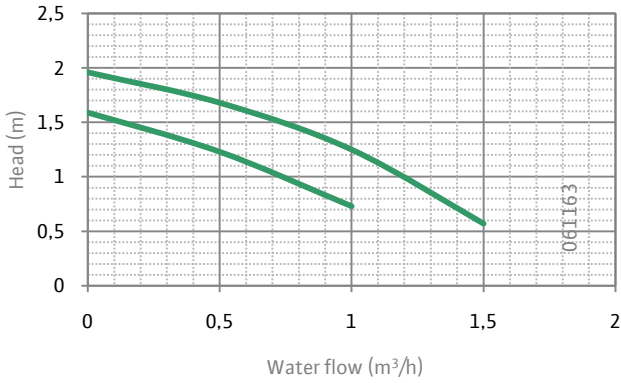

ZRS ../-4-3 Ku

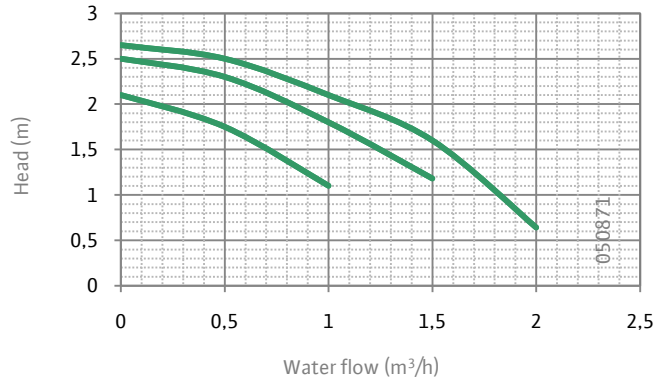

ZRS ../-6-3 Ku

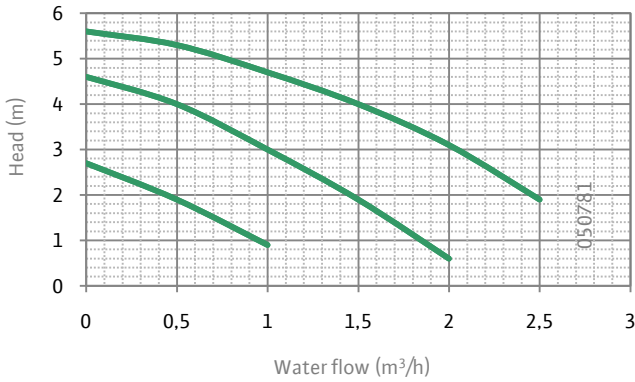

ZRS ../-7-3 Ku

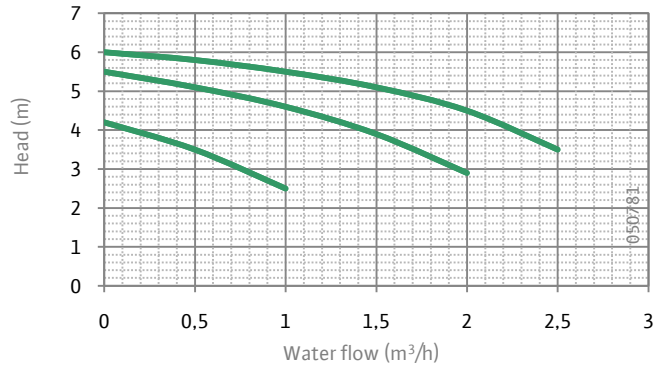

Asynchronous circulators for sanitary application

Type : NSB10 / NSB15

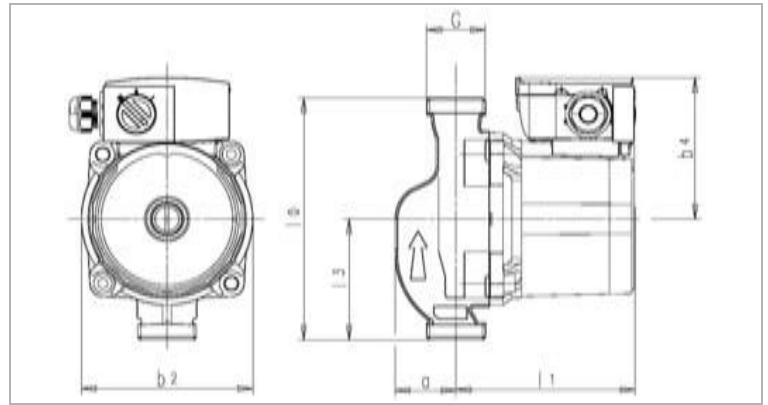

NSB10-15B

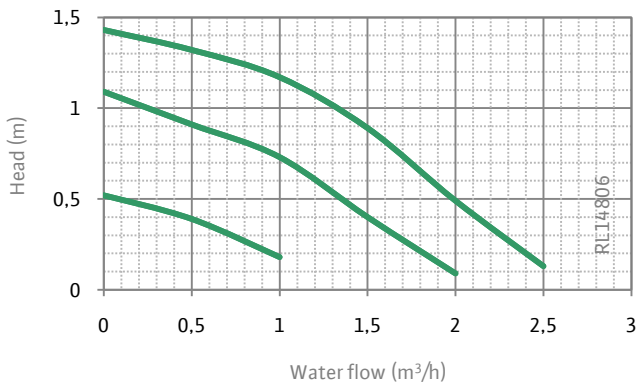

NSB15-15B

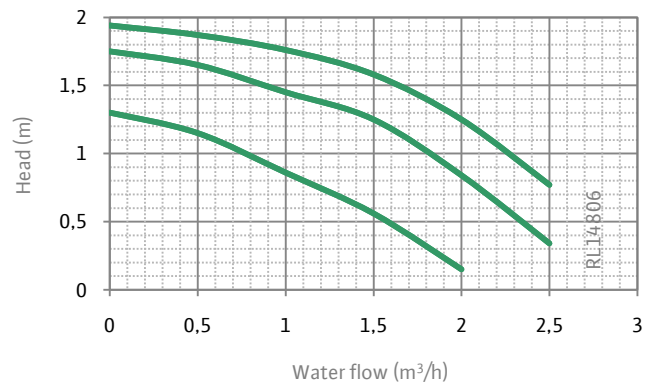

	n l/m	PI W	I A	Capacitor µf/VDB
NSB10-15B	max	2000	48	1.6 / 400
		1600	32	
	min	1000	20	
NSB15-15B	max	2500	56	2 / 400
		2200	39	
	min	1700	27	

	Thread	Dimensions					
	G	l0	l3	l1	a	b2	b4
NSB10-15B	1"	130	65	96.6	32.2	92.5	72.5
NSB15-15B							

Asynchronous circulators for sanitary application

Type : NSB25 / NSB30

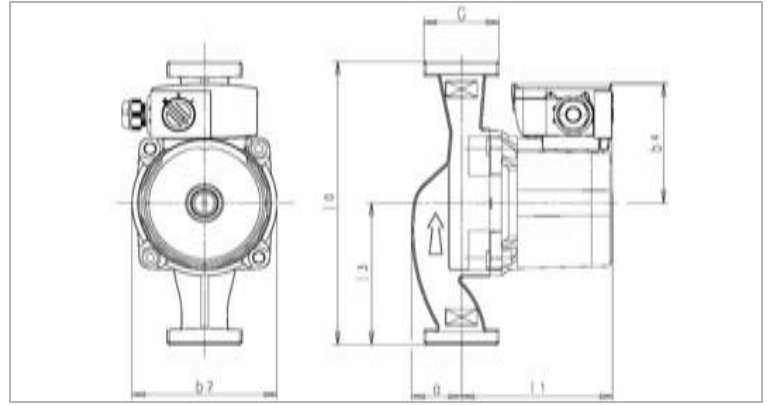

NSB25-20B

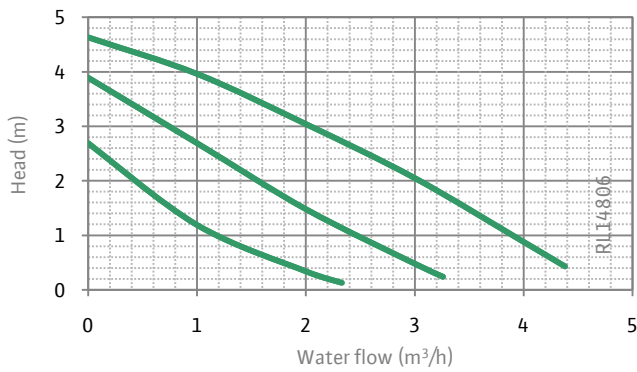

NSB30-25B

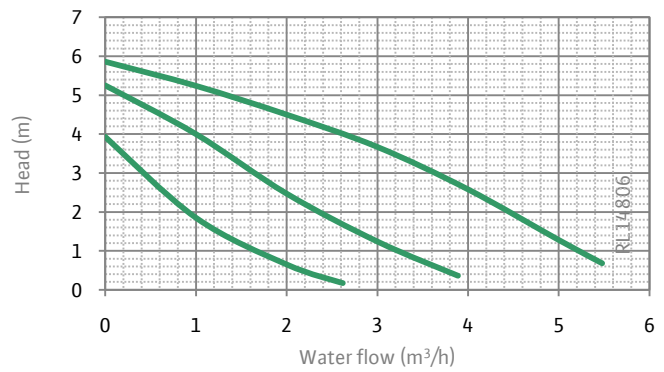

	n		P1 W	I A	Capacitor µF / VDB
	1/min				
NSB25-20B	max	1950	89	0,39	2,6 / 400
	min	1000	66	0,29	
NSB30-25B	max	2300	114	0,50	2,6 / 400
	min	1150	102	0,46	
			70	0,32	

	Thread		Dimensions				
	G	I0	I3	I1	a	b2	b4
NSB25-20B	1"1/4	158	79	96,6	33,2	92,5	76
NSB30-25B	1"1/2	180	90	96,6	33,2	92,5	76

Solar thermal energy systems



Asynchronous circulators for solar application

Type ST../4.5 ECO , ST../6 ECO and ST../7 ECO

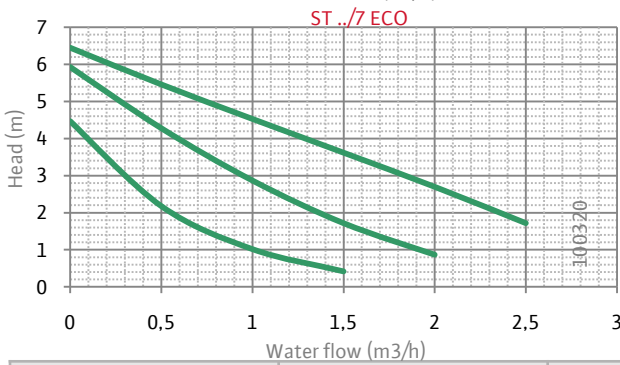
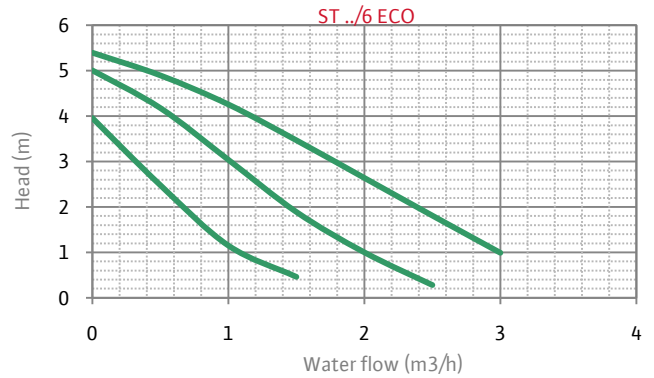
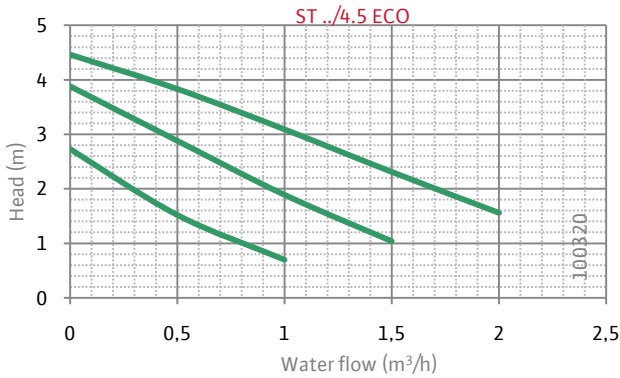
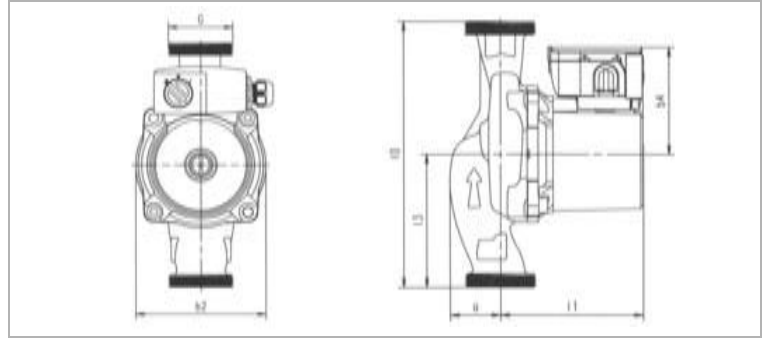
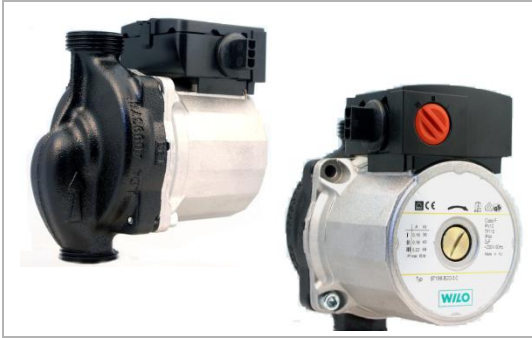

	Speed	P1 (500l/h) W	I (500l/h) A	Capacitor µF / VDB
ST../4.5 ECO	max	43	0,18	1,7 / 400
	med	35	0,15	
	min	26	0,12	
ST../6 ECO	max	49	0,22	2 / 400
	med	43	0,19	
	min	36	0,16	
ST../7 ECO	max	53	0,23	2 / 400
	med	47	0,20	
	min	39	0,17	

	Thread		Dimensions				
	G	l0	l1	l3	a	b2	b4
ST15/4.5 ECO	1"	130		65	32,8	93	
ST25/4.5 ECO	1"1/2	130	96,6	65	33,4	93	72,5
ST25/4.5 ECO	1"1/2	180		90	34	95,5	
ST15/6 ECO	1"	130		65	32,8	93	
ST25/6 ECO	1"1/2	130	96,6	65	33,4	93	76
ST25/6 ECO	1"1/2	180		90	34	95,5	
ST15/7 ECO	1"	130		65	28,1	92,5	
ST25/7 ECO	1"1/2	130	96,6	65	33,8	92,5	76
ST25/7 ECO	1"1/2	180		90	31,7	92,5	

Asynchronous circulators for solar application

Type ST15/8 ECO

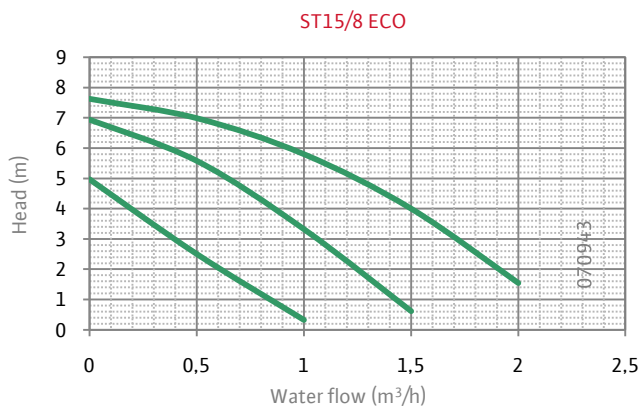
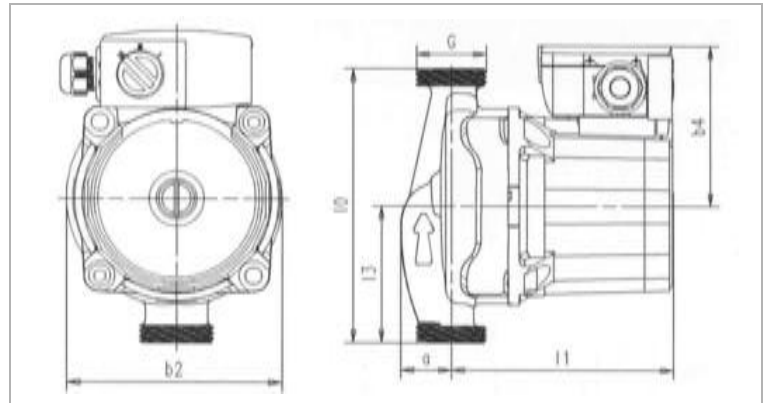

	Speed	P1 (500l/h) W	I (500l/h) A	Capacitor µF /VDB
ST15/8 ECO	max	86	0,37	3 /400
	med	53	0,26	
	min	47	0,21	

	Thread	Dimensions					
	G	I0	I1	I3	a	b2	b4
ST15/8 ECO	1"	130	105,4	65	24	97	76

Asynchronous circulators for solar application

Type ST/8 High flow

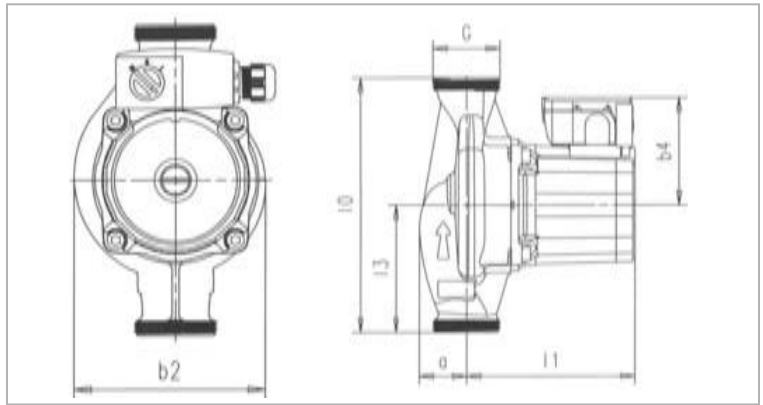

ST/8

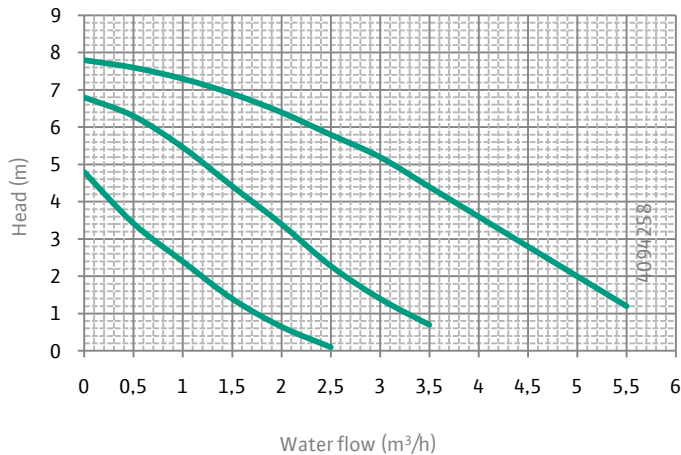

	n l/min	P1 W	I A	Capacitor μ F / VDB
ST25/8 ST30/8	Max	2400	151	3,5 / 400
		2100	113	
	Min	1800	81	

	Thread	Dimensions					
	G	l0	l1	l3	a	b2	b4
ST25/8	1"1/2	180	119	90	33,3	111	76
ST30/8	2"	180	119	90	33,3	111,5	76

Nota bene : Pump approved for TF 95.
Up to 50h/a at 110°C (max 2h/d) water temperature acceptable during pump operation
Up to 50h/life time at 140°C water temperature acceptable without pump operation (stagnation)

Asynchronous circulators for solar application

Type ST15/9 and ST15/11

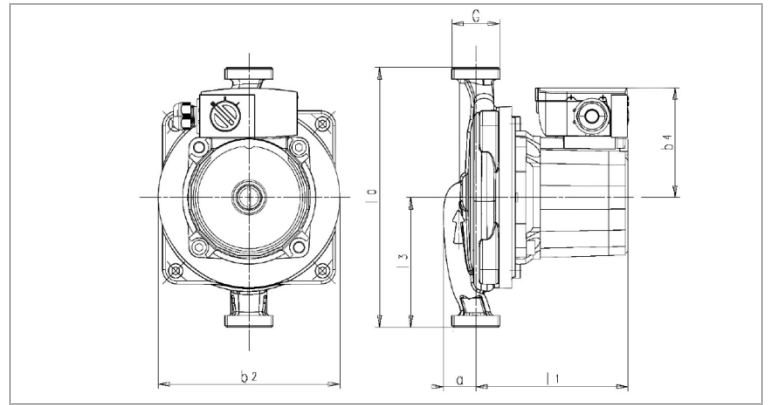

ST15/9

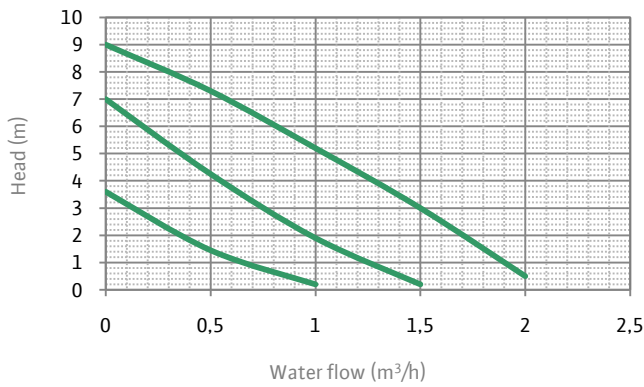

ST15/11

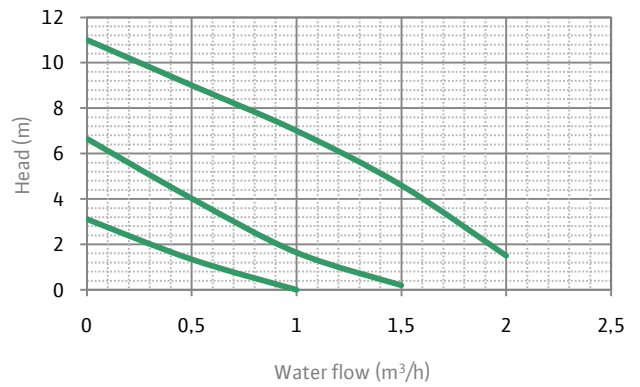

	n l/min	P1 W	I A	Capacitor µF / VDB
ST15/9	max	2100	110	3 / 400
		1600	78	
	min	1100	50	
ST15/11	max	2500	165	3,5 / 400
		2100	115	
	min	1500	75	

	Thread	Dimensions					
	G	l0	l1	l3	a	b2	b4
ST15/9	1"	180	105,4	90	23,6	130,4	76
ST15/11	1"	180	118,4	90	23,6	130,4	76

Inline asynchronous circulators for solar application

Type : TOP S

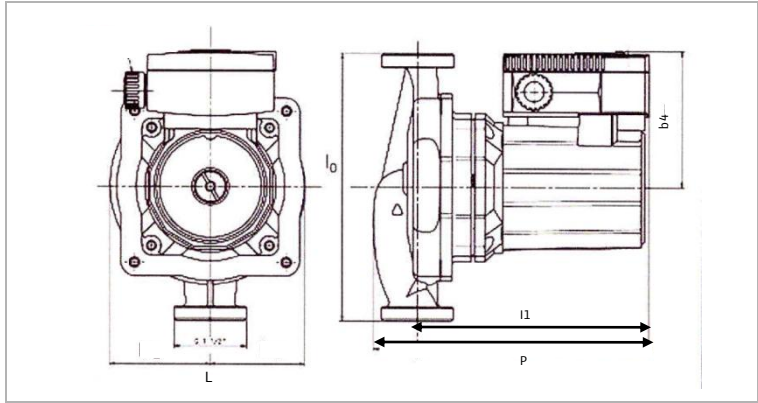

Wiring diagram

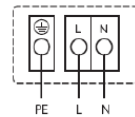

Internal protection against unacceptably high winding temperatures

Tripping: Internal interruption of motor voltage

Reset: Automatic after motor has cooled down

TOP-S25/13

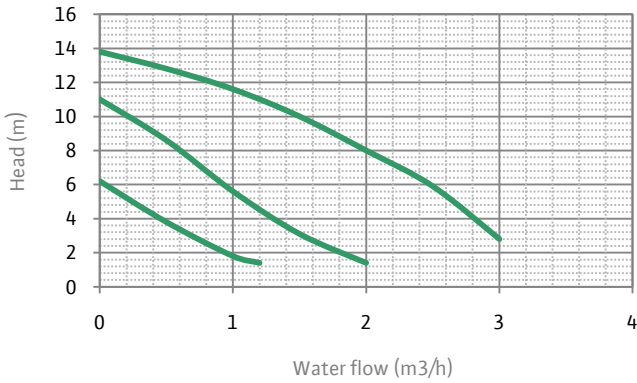

	Steps	n 1/min	P1 W	I A	Capacitor µF /VDB
TOP-S 25/13	max	2680	260	1,24	6 /400
		2380	200	0,96	
	min	1800	130	0,65	

	Thread	Dimensions					
	G	I0	I3	P	I1	L	b4
TOP-S 25/13	1"1/2	180	92	186	156	131	92

Geothermal energy systems



Asynchronous circulators for heat pump application

Type RSG../6 and ../7

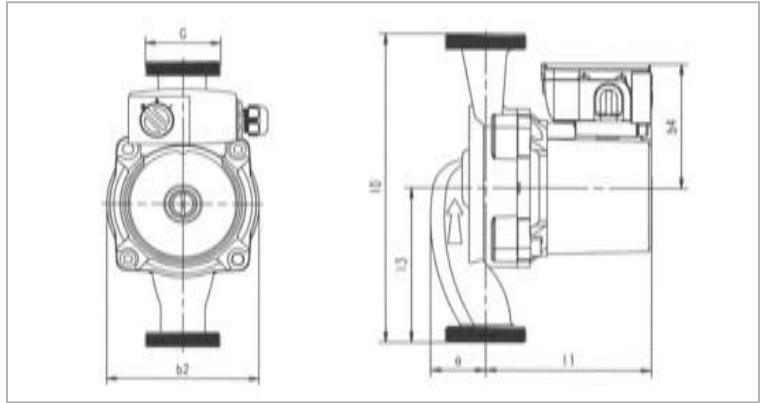

RSG../6

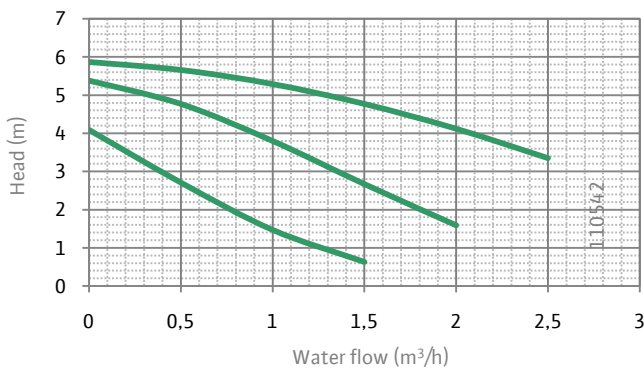

RSG../7

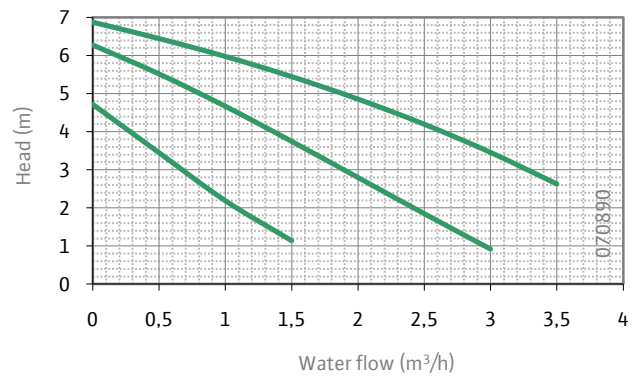

	Speed	P1 W	I A	Capacitor µf/VDB
RSG../6	max	93	0,40	2,6 / 400
	med	67	0,30	
	min	46	0,20	
RSG../7	max	132	0,58	3,5 / 400
	med	92	0,42	
	min	62	0,30	

	Thread	Dimensions					
	G	l0	l1	l3	a	b2	b4
RSG15/6	1"	130		65			
RSG25/6	1"1/2	130	96,6	65	28,1	92,5	76
RSG25/6	1"1/2	180		90			
RSG15/7	1"	130		65			
RSG25/7	1"1/2	130	109,6	65	28,1	92,5	76
RSG25/7	1"1/2	180		90			

Asynchronous circulators for heat pump application

Type RSG/8

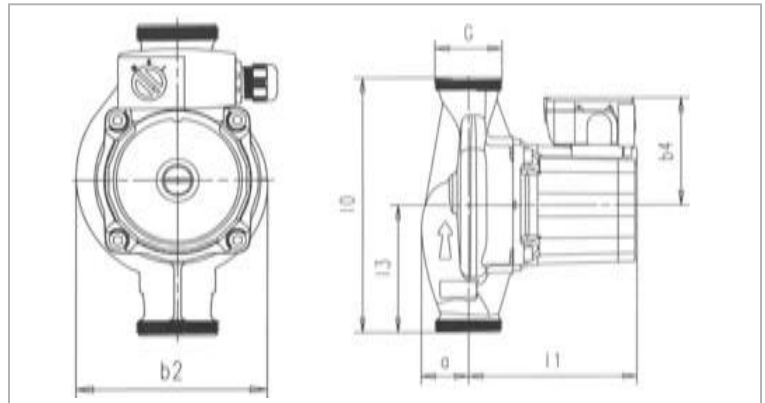

RSG/8

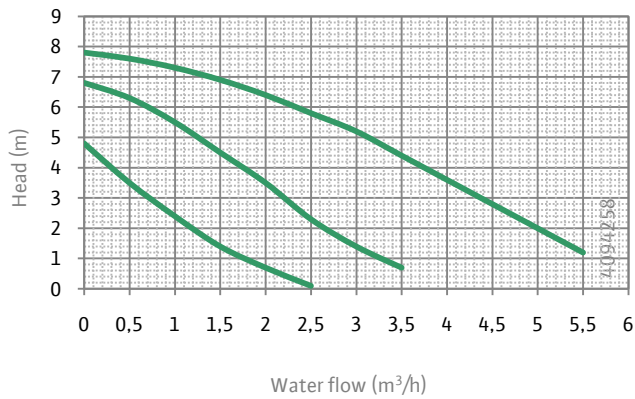

	n 1/min	P1 W	I A	Capacitor μF/ VDB
RSG../8	max	2400	151	3,5 / 400
		2100	113	
	min	1800	81	

	Thread	Dimensions					
	G	l0	l1	l3	a	b2	b4
RSG25/8	1"1/2	180	119	90	33,3	111	76
RSG30/8	2"	180	119	90	33,3	111,5	76

Wilointec

50 av. Casella
F-18700 Aubigny sur Nère
Tel : +33 2 48 81 62 62
Fax : +33 2 48 58 20 29
www.wilointec.com

information@wilointec.com

Sales & Marketing Director

Vincent Fleurier
Tel : +33 2 48 81 62 74
Fax : +33 2 48 58 20 29
vincent.fleurier@wilointec.com

Sales Administration Manager

Véronique Martin
Tel : +33 2 48 81 62 75
Fax : +33 2 48 58 20 29
veronique.martin@wilointec.com

Sales Manager France & Spain

Robert Carre
Tel : +33 2 48 81 62 72
Fax : +33 2 48 58 20 29
robert.carre@wilointec.com

Sales Manager Italy

Dario Frazza
Tel : +39 335 762 6181
Fax : +39 059 286 0855
dario.frazza@wilointec.com

Sales Manager Subsidiaries

Gilles Moulin
Tel : +33 2 48 81 62 25
Fax : +33 2 48 58 20 29
gilles.moulin@wilointec.com

Sales Manager Germany

Thomas Merscheim
Tel : +49 172 352 3933
Fax : +49 231 410 2578
thomas.merscheim@wilo.de

Sales Manager UK

Kevin Padmore
Tel : +44 776 801 8879
Fax : +44 128 373 2380
kevin.padmore@wilointec.com

Sales Manager Benelux

Ronald Rijkhoff
Tel : +31 653 126 749
Fax : +31 251 215 214
ronald.rijkhoff@wilo.nl